



## **XS** Cable Management Systems

Light & Medium Duty Cable Ladder

- Patented Roll Formed Profile
- Fast and Easy Installation
- Flexible Layout Feasibility
- Customized Solution
- Off the Shelf Availability
- Choice of Accessories
- ***Xtra Strength***
- ***Xtra Stability***
- ***Xtensive Solution***
- ***X Stock***



# A Perfect Solution

An Engineered Product with  
Quality, Consistency and  
Cost Effectiveness.

Standardized products equipped with  
robust technology and emphasizing on  
the safety aspects without compromising  
on load bearing capacity.

# ICONS

## Cable Ladder Finishes

<b>A</b>	Alu Zinc & Magnesium
<b>4</b>	AISI 304 Stainless Steel
<b>6</b>	AISI 316 Stainless Steel
<b>8</b>	AISI 316 L Stainless Steel

<b>G</b>	Pre-Galvanized
<b>H</b>	Hot-Dip Galvanized
<b>P</b>	Powder Coated

## Items

## Dimensions

Y (XS Ladder)  
 C (Conventional Cover)  
 Z (XS Ladder Cover)  
 A (Not applicable)  
 t (Thickness in mm)  
 l (Length in mm)  
 B (Bolted)  
 W (Welded)

Widths (W)		Height (H)	
50 mm	05	75 mm	7
75 mm	07	100 mm	1
100 mm	10		
150 mm	15		
200 mm	20		
300 mm	30		
400 mm	40		
450 mm	45		
500 mm	50		
600 mm	60		
750 mm	75		
900 mm	90		

\* All Dimensions are in millimeters (mm)

## Accessories

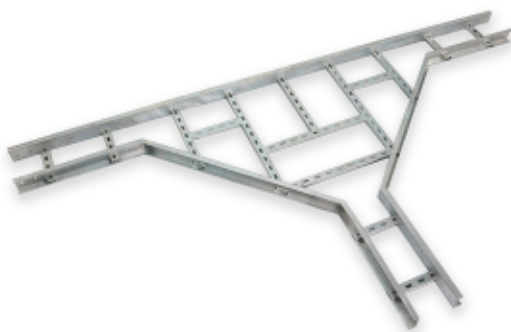

TB (Tee Bend)  
 H3 (30° Horizontal Bend)  
 H4 (45° Horizontal Bend)  
 H9 (90° Horizontal Bend)  
 V3 (30° Vertical Bend)  
 V4 (45° Vertical Bend)  
 V9 (90° Vertical Bend)  
 CB (Cross Bend)  
 RL (Reducer Left)  
 RR (Reducer Right)  
 RE (Reducer Equal)  
 VU (Vertical Up Bend)  
 VD (Vertical Down Bend)  
 ET (Extension Tee)

# CABLE LADDER SPECIFICATIONS .....

## Cable Ladder Design & Manufacture

---

Niedax's Cable Ladder systems are designed and manufactured according to National (Indian Standard, CPRI) and International Standards (Such as NEMA VE1 and IEC 61537).

### Material

#### **Pre-Galvanised Steel:**

Ladders shall meet the minimum yield and tensile strength of the ASTM standards (ASTM A653) with G 90 coating thickness.

#### **Hot-Dip Galvanised Steel:**

Ladders are Hot-Dip Galvanised in accordance with ASTM A123.

#### **Stainless Steel:**

Ladders are constructed of AISI type 304, type 316 or type 316 L stainless steel.

#### **Powder Coated:**

Ladders are pre-treated and powder coated as per IEC Standards.

#### **Alu Zinc + Magnesium:**

Ladders with Zinc-Aluminium-Magnesium coating are ideal for multiple engineering applications where good corrosion resistance in very aggressive environments is required. Due to its unique composition it offers a self healing property on cut edges.

#### **HRCA (Hot Rolled and Close Annealed):**

Ladders are made of hot roll steel which shall meet IS2062 standard.

#### **CRCA (Cold Rolled Close Annealed):**

Ladders are made of cold roll steel which shall meet IS513 standard.

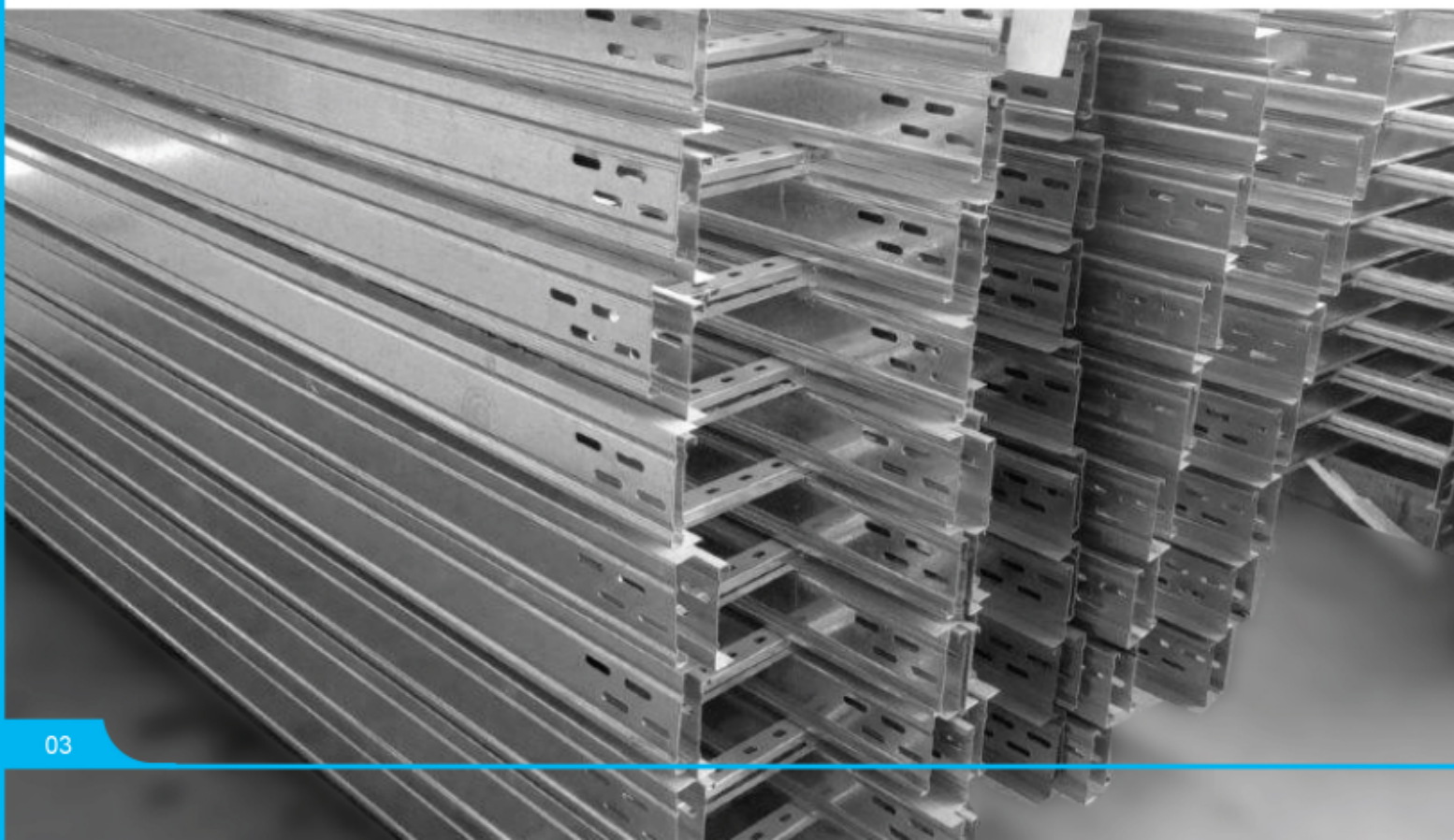

## XS Range Profile Type Cable Ladder

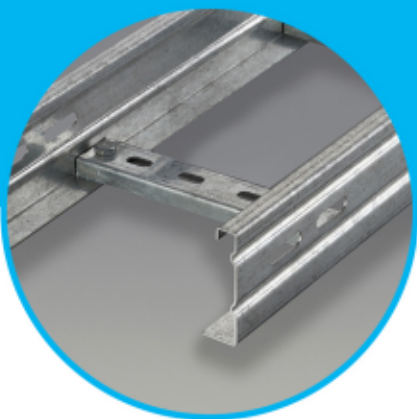

Rolled Flange For  
Extra Stability

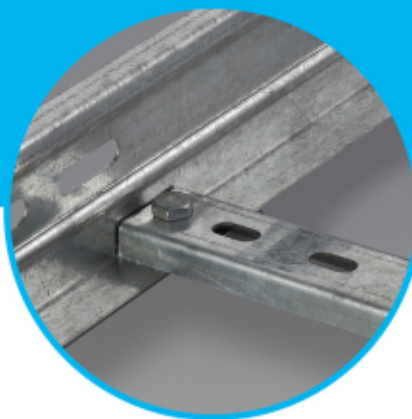

Bottom Groove  
Support Rungs To  
Prevent Inwards  
Bending

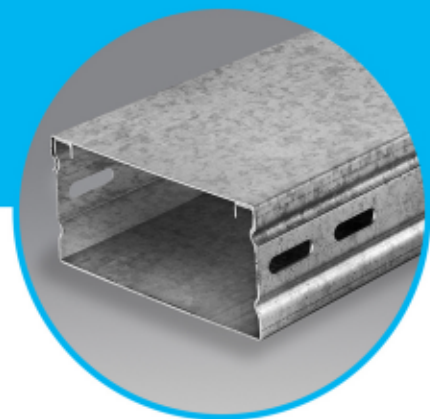

Snap On  
Cover

# CABLE LADDER DIMENSIONS



## Welded Type Cable Ladder

Finish	Tray Model No.	Cover Model No.	Width (W) mm	Height (H) mm
G	YW107tIG	ZN100tIG	100	75
G	YW157tIG	ZN150tIG	150	75
G	YW207tIG	ZN200tIG	200	75
G	YW307tIG	ZN300tIG	300	75
G	YW457tIG	ZN450tIG	450	75
G	YW607tIG	ZN600tIG	600	75
G	YW757tIG	ZN750tIG	750	75
G	YW907tIG	ZN900tIG	900	75
H	YW107tIH	ZN100tIH	100	75
H	YW157tIH	ZN150tIH	150	75
H	YW207tIH	ZN200tIH	200	75
H	YW307tIH	ZN300tIH	300	75
H	YW457tIH	ZN450tIH	450	75
H	YW607tIH	ZN600tIH	600	75
H	YW757tIH	ZN750tIH	750	75
H	YW907tIH	ZN900tIH	900	75
A	Alu Zinc & Magnesium	These finishes are available upon request.		
4	AISI 304			
6	AISI 316			
8	AISI 316 L			
P	Powder Coated			

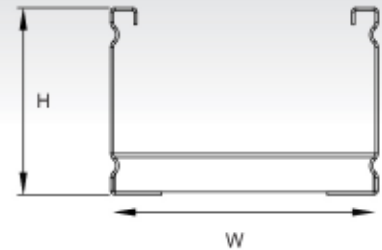

## Welded Type Cable Ladder

Finish	Tray Model No.	Cover Model No.	Width (W) mm	Height (H) mm
G	YW101tIG	ZN100tIG	100	100
G	YW151tIG	ZN150tIG	150	100
G	YW201tIG	ZN200tIG	200	100
G	YW301tIG	ZN300tIG	300	100
G	YW451tIG	ZN450tIG	450	100
G	YW601tIG	ZN600tIG	600	100
G	YW751tIG	ZN750tIG	750	100
G	YW901tIG	ZN900tIG	900	100
H	YW101tIH	ZN100tIH	100	100
H	YW151tIH	ZN150tIH	150	100
H	YW201tIH	ZN200tIH	200	100
H	YW301tIH	ZN300tIH	300	100
H	YW451tIH	ZN450tIH	450	100
H	YW601tIH	ZN600tIH	600	100
H	YW751tIH	ZN750tIH	750	100
H	YW901tIH	ZN900tIH	900	100
A	Alu Zinc & Magnesium	These finishes are available upon request.		
4	AISI 304			
6	AISI 316			
8	AISI 316 L			
P	Powder Coated			

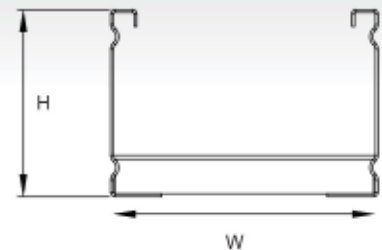

### Bolted Type Cable Ladder

Finish	Tray Model No.	Cover Model No.	Width (W) mm	Height (H) mm
G	YB107tIG	ZN100tIG	100	75
G	YB157tIG	ZN150tIG	150	75
G	YB207tIG	ZN200tIG	200	75
G	YB307tIG	ZN300tIG	300	75
G	YB457tIG	ZN450tIG	450	75
G	YB607tIG	ZN600tIG	600	75
G	YB757tIG	ZN750tIG	750	75
G	YB907tIG	ZN900tIG	900	75
H	YB107tIH	ZN100tIH	100	75
H	YB157tIH	ZN150tIH	150	75
H	YB207tIH	ZN200tIH	200	75
H	YB307tIH	ZN300tIH	300	75
H	YB457tIH	ZN450tIH	450	75
H	YB607tIH	ZN600tIH	600	75
H	YB757tIH	ZN750tIH	750	75
H	YB907tIH	ZN900tIH	900	75
A	Alu Zinc & Magnesium			
4	AISI 304			
6	AISI 316			
8	AISI 316 L			
P	Powder Coated			

These finishes are available upon request.

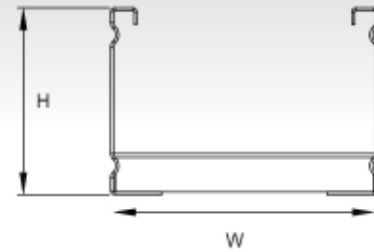

### Bolted Type Cable Ladder

Finish	Tray Model No.	Cover Model No.	Width (W) mm	Height (H) mm
G	YB101tIG	ZN100tIG	100	100
G	YB151tIG	ZN150tIG	150	100
G	YB201tIG	ZN200tIG	200	100
G	YB301tIG	ZN300tIG	300	100
G	YB451tIG	ZN450tIG	450	100
G	YB601tIG	ZN600tIG	600	100
G	YB751tIG	ZN750tIG	750	100
G	YB901tIG	ZN900tIG	900	100
H	YB101tIH	ZN100tIH	100	100
H	YB151tIH	ZN150tIH	150	100
H	YB201tIH	ZN200tIH	200	100
H	YB301tIH	ZN300tIH	300	100
H	YB451tIH	ZN450tIH	450	100
H	YB601tIH	ZN600tIH	600	100
H	YB751tIH	ZN750tIH	750	100
H	YB901tIH	ZN900tIH	900	100
A	Alu Zinc & Magnesium			
4	AISI 304			
6	AISI 316			
8	AISI 316 L			
P	Powder Coated			

These finishes are available upon request.

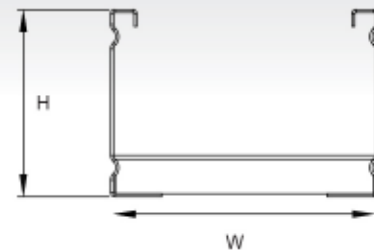

# CABLE LADDER DIMENSIONS



## Cable Ladders' Accessories Range

### 45° Horizontal Bend

Finish	Tray Model No.	Cover Model No.	Width (W) mm	Height (H) mm
G	LW107t0GH4	CN100t0GH4	100	75
G	LW157t0GH4	CN150t0GH4	150	75
G	LW207t0GH4	CN200t0GH4	200	75
G	LW307t0GH4	CN300t0GH4	300	75
G	LW457t0GH4	CN450t0GH4	450	75
G	LW607t0GH4	CN600t0GH4	600	75
G	LW757t0GH4	CN750t0GH4	750	75
G	LW907t0GH4	CN900t0GH4	900	75
H	LW107t0HH4	CN100t0HH4	100	75
H	LW157t0HH4	CN150t0HH4	150	75
H	LW207t0HH4	CN200t0HH4	200	75
H	LW307t0HH4	CN300t0HH4	300	75
H	LW457t0HH4	CN450t0HH4	450	75
H	LW607t0HH4	CN600t0HH4	600	75
H	LW757t0HH4	CN750t0HH4	750	75
H	LW907t0HH4	CN900t0HH4	900	75
A	Alu Zinc & Magnesium	These finishes are available upon request.		
4	AISI 304			
6	AISI 316			
8	AISI 316 L			
P	Powder Coated			

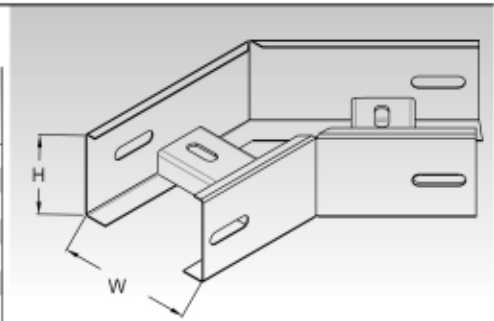

### 45° Vertical Bend

Finish	Tray Model No.	Cover Model No.	Width (W) mm	Height (H) mm
G	LW107t0GV4	CN100t0GV4	100	75
G	LW157t0GV4	CN150t0GV4	150	75
G	LW207t0GV4	CN200t0GV4	200	75
G	LW307t0GV4	CN300t0GV4	300	75
G	LW457t0GV4	CN450t0GV4	450	75
G	LW607t0GV4	CN600t0GV4	600	75
G	LW757t0GV4	CN750t0GV4	750	75
G	LW907t0GV4	CN900t0GV4	900	75
H	LW107t0HV4	CN100t0HV4	100	75
H	LW157t0HV4	CN150t0HV4	150	75
H	LW207t0HV4	CN200t0HV4	200	75
H	LW307t0HV4	CN300t0HV4	300	75
H	LW457t0HV4	CN450t0HV4	450	75
H	LW607t0HV4	CN600t0HV4	600	75
H	LW757t0HV4	CN750t0HV4	750	75
H	LW907t0HV4	CN900t0HV4	900	75
A	Alu Zinc & Magnesium	These finishes are available upon request.		
4	AISI 304			
6	AISI 316			
8	AISI 316 L			
P	Powder Coated			

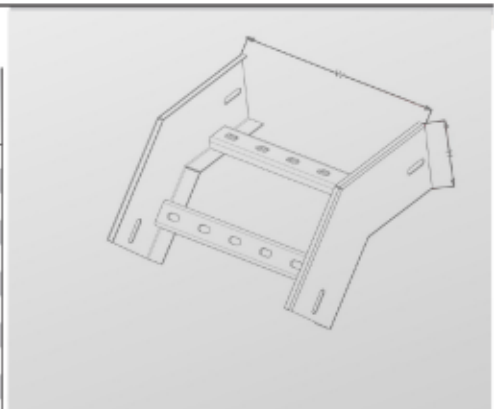



**Cable Ladders' Accessories Range**
**TB (Tee Bend)**

Finish	Tray Model No.	Cover Model No.	Width (W) mm	Height (H) mm
G	LW107t0GTB	CN100t0GTB	100	75
G	LW157t0GTB	CN150t0GTB	150	75
G	LW207t0GTB	CN200t0GTB	200	75
G	LW307t0GTB	CN300t0GTB	300	75
G	LW457t0GTB	CN450t0GTB	450	75
G	LW607t0GTB	CN600t0GTB	600	75
G	LW757t0GTB	CN750t0GTB	750	75
G	LW907t0GTB	CN900t0GTB	900	75
H	LW107t0HTB	CN100t0HTB	100	75
H	LW157t0HTB	CN150t0HTB	150	75
H	LW207t0HTB	CN200t0HTB	200	75
H	LW307t0HTB	CN300t0HTB	300	75
H	LW457t0HTB	CN450t0HTB	450	75
H	LW607t0HTB	CN600t0HTB	600	75
H	LW757t0HTB	CN750t0HTB	750	75
H	LW907t0HTB	CN900t0HTB	900	75
A	Alu Zinc & Magnesium	These finishes are available upon request.		
4	AISI 304			
6	AISI 316			
8	AISI 316 L			
P	Powder Coated			

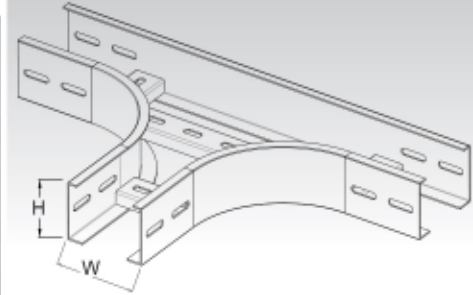
**CB (Cross Bend)**

Finish	Tray Model No.	Cover Model No.	Width (W) mm	Height (H) mm
G	LW107t0GCB	CN100t0GCB	100	75
G	LW157t0GCB	CN150t0GCB	150	75
G	LW207t0GCB	CN200t0GCB	200	75
G	LW307t0GCB	CN300t0GCB	300	75
G	LW457t0GCB	CN450t0GCB	450	75
G	LW607t0GCB	CN600t0GCB	600	75
G	LW757t0GCB	CN750t0GCB	750	75
G	LW907t0GCB	CN900t0GCB	900	75
H	LW107t0HCB	CN100t0HCB	100	75
H	LW157t0HCB	CN150t0HCB	150	75
H	LW207t0HCB	CN200t0HCB	200	75
H	LW307t0HCB	CN300t0HCB	300	75
H	LW457t0HCB	CN450t0HCB	450	75
H	LW607t0HCB	CN600t0HCB	600	75
H	LW757t0HCB	CN750t0HCB	750	75
H	LW907t0HCB	CN900t0HCB	900	75
A	Alu Zinc & Magnesium	These finishes are available upon request.		
4	AISI 304			
6	AISI 316			
8	AISI 316 L			
P	Powder Coated			

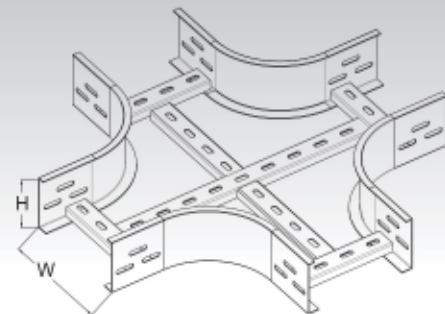

# CABLE LADDER DIMENSIONS

## Cable Ladders' Accessories Range

### RL (Reducer Left)

Finish	Tray Model No.	Cover Model No.	Width (W1) mm	Width (W2) mm	Height (H) mm
G	LW157t0GRL10	CN150t0GRL10	150	100	75
G	LW207t0GRL15	CN200t0GRL15	200	150	75
G	LW307t0GRL20	CN300t0GRL20	300	200	75
G	LW457t0GRL30	CN450t0GRL30	450	300	75
G	LW607t0GRL45	CN600t0GRL45	600	450	75
G	LW757t0GRL60	CN750t0GRL60	750	600	75
G	LW907t0GRL75	CN900t0GRL75	900	750	75
H	LW157t0HRL10	CN150t0HRL10	150	100	75
H	LW207t0HRL15	CN200t0HRL15	200	150	75
H	LW307t0HRL20	CN300t0HRL20	300	200	75
H	LW457t0HRL30	CN450t0HRL30	450	300	75
H	LW607t0HRL45	CN600t0HRL45	600	450	75
H	LW757t0HRL60	CN750t0HRL60	750	600	75
H	LW907t0HRL75	CN900t0HRL75	900	750	75
A	Alu Zinc & Magnesium	These finishes are available upon request.			
4	AISI 304				
6	AISI 316				
8	AISI 316 L				
P	Powder Coated				

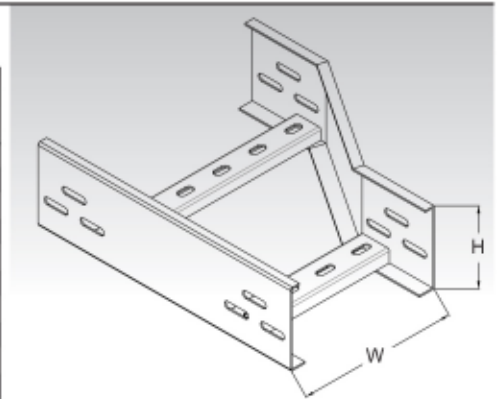

### RR (Reducer Right)

Finish	Tray Model No.	Cover Model No.	Width (W1) mm	Width (W2) mm	Height (H) mm
G	LW157t0GRR10	CN150t0GRR10	150	100	75
G	LW207t0GRR15	CN200t0GRR15	200	150	75
G	LW307t0GRR20	CN300t0GRR20	300	200	75
G	LW457t0GRR30	CN450t0GRR30	450	300	75
G	LW607t0GRR45	CN600t0GRR45	600	450	75
G	LW757t0GRR60	CN750t0GRR60	750	600	75
G	LW907t0GRR75	CN900t0GRR75	900	750	75
H	LW157t0HRR10	CN150t0HRR10	150	100	75
H	LW207t0HRR15	CN200t0HRR15	200	150	75
H	LW307t0HRR20	CN300t0HRR20	300	200	75
H	LW457t0HRR30	CN450t0HRR30	450	300	75
H	LW607t0HRR45	CN600t0HRR45	600	450	75
H	LW757t0HRR60	CN750t0HRR60	750	600	75
H	LW907t0HRR75	CN900t0HRR75	900	750	75
A	Alu Zinc & Magnesium	These finishes are available upon request.			
4	AISI 304				
6	AISI 316				
8	AISI 316 L				
P	Powder Coated				

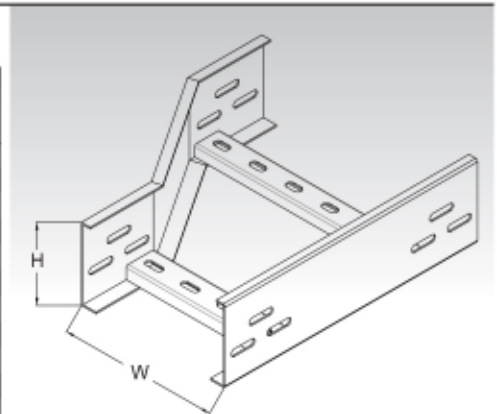

**Cable Ladders' Accessories Range**
**RE (Reducer Equal)**

Finish	Tray Model No.	Cover Model No.	Width (W1) mm	Width (W1) mm	Height (H) mm
G	LW157t0GRE10	CN150t0GRE10	150	100	75
G	LW207t0GRE15	CN200t0GRE15	200	150	75
G	LW307t0GRE20	CN300t0GRE20	300	200	75
G	LW457t0GRE30	CN450t0GRE30	450	300	75
G	LW607t0GRE45	CN600t0GRE45	600	450	75
G	LW757t0GRE60	CN750t0GRE60	750	600	75
G	LW907t0GRE75	CN900t0GRE75	900	750	75
H	LW157t0HRE10	CN150t0HRE10	150	100	75
H	LW207t0HRE15	CN200t0HRE15	200	150	75
H	LW307t0HRE20	CN300t0HRE20	300	200	75
H	LW457t0HRE30	CN450t0HRE30	450	300	75
H	LW607t0HRE45	CN600t0HRE45	600	450	75
H	LW757t0HRE60	CN750t0HRE60	750	600	75
H	LW907t0HRE75	CN900t0HRE75	900	750	75
A	Alu Zinc & Magnesium	These finishes are available upon request.			
4	AISI 304				
6	AISI 316				
8	AISI 316 L				
P	Powder Coated				

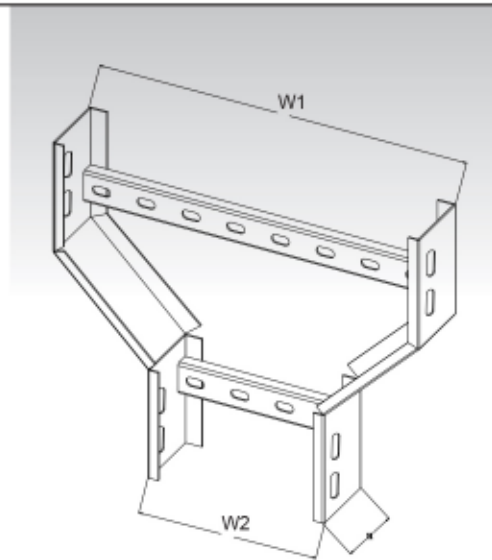
**VU (Vertical Up Bend)**

Finish	Tray Model No.	Cover Model No.	Width (W) mm	Height (H) mm
G	LW107t0GVU	CN100t0GVU	100	75
G	LW157t0GVU	CN150t0GVU	150	75
G	LW207t0GVU	CN200t0GVU	200	75
G	LW307t0GVU	CN300t0GVU	300	75
G	LW457t0GVU	CN450t0GVU	450	75
G	LW607t0GVU	CN600t0GVU	600	75
G	LW757t0GVU	CN750t0GVU	750	75
G	LW907t0GVU	CN900t0GVU	900	75
H	LW107t0HVU	CN100t0HVU	100	75
H	LW157t0HVU	CN150t0HVU	150	75
H	LW207t0HVU	CN200t0HVU	200	75
H	LW307t0HVU	CN300t0HVU	300	75
H	LW457t0HVU	CN450t0HVU	450	75
H	LW607t0HVU	CN600t0HVU	600	75
H	LW757t0HVU	CN750t0HVU	750	75
H	LW907t0HVU	CN900t0HVU	900	75
A	Alu Zinc & Magnesium	These finishes are available upon request.		
4	AISI 304			
6	AISI 316			
8	AISI 316 L			
P	Powder Coated			

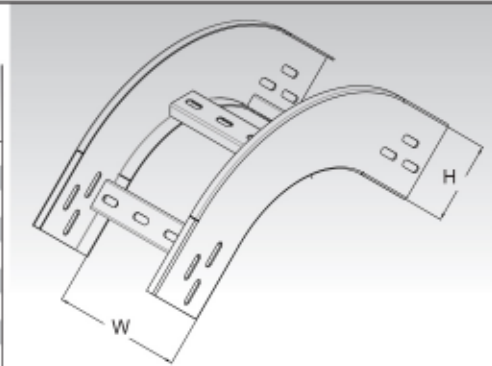

# CABLE LADDER DIMENSIONS

## Cable Ladders' Accessories Range

### VD(Vertical Down Bend)

Finish	Tray Model No.	Cover Model No.	Width(W) mm	Height(H) mm
G	LW107t0GVD	CN100t0GVD	100	75
G	LW157t0GVD	CN150t0GVD	150	75
G	LW207t0GVD	CN200t0GVD	200	75
G	LW307t0GVD	CN300t0GVD	300	75
G	LW457t0GVD	CN450t0GVD	450	75
G	LW607t0GVD	CN600t0GVD	600	75
G	LW757t0GVD	CN750t0GVD	750	75
G	LW907t0GVD	CN900t0GVD	900	75
H	LW107t0HVD	CN100t0HVD	100	75
H	LW157t0HVD	CN150t0HVD	150	75
H	LW207t0HVD	CN200t0HVD	200	75
H	LW307t0HVD	CN300t0HVD	300	75
H	LW457t0HVD	CN450t0HVD	450	75
H	LW607t0HVD	CN600t0HVD	600	75
H	LW757t0HVD	CN750t0HVD	750	75
H	LW907t0HVD	CN900t0HVD	900	75
A	Alu Zinc & Magnesium	These finishes are available upon request.		
4	AISI 304			
6	AISI 316			
8	AISI 316 L			
P	Powder Coated			

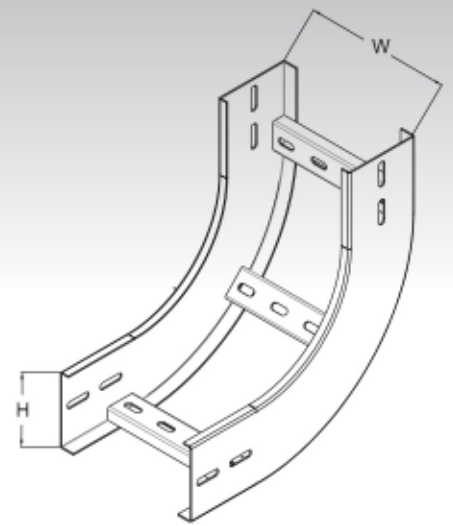

### ET (Extension Tee)

Finish	Tray Model No.	Cover Model No.	Width(W) mm	Height(H) mm
G	LW107t0GET	CN100t0GET	100	75
G	LW157t0GET	CN150t0GET	150	75
G	LW207t0GET	CN200t0GET	200	75
G	LW307t0GET	CN300t0GET	300	75
G	LW457t0GET	CN450t0GET	450	75
G	LW607t0GET	CN600t0GET	600	75
G	LW757t0GET	CN750t0GET	750	75
G	LW907t0GET	CN900t0GET	900	75
H	LW107t0HET	CN100t0HET	100	75
H	LW157t0HET	CN150t0HET	150	75
H	LW207t0HET	CN200t0HET	200	75
H	LW307t0HET	CN300t0HET	300	75
H	LW457t0HET	CN450t0HET	450	75
H	LW607t0HET	CN600t0HET	600	75
H	LW757t0HET	CN750t0HET	750	75
H	LW907t0HET	CN900t0HET	900	75
A	Alu Zinc & Magnesium	These finishes are available upon request.		
4	AISI 304			
6	AISI 316			
8	AISI 316 L			
P	Powder Coated			

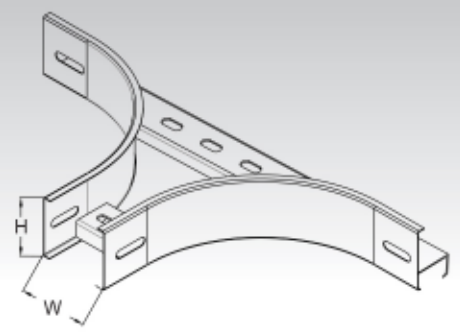

Product height customization options are available depending upon request.

#### Standard thickness:

- 1.6 (0.8, 1.0, 1.2, 1.8 & 2.0 available on request)
- Upto 1.6 mm thickness is available for SS and Pre-Galvanized materials
- Upto 2 mm thickness is available for Hot-Dip Galvanized materials

Standard Length upto 3 mtrs is available.

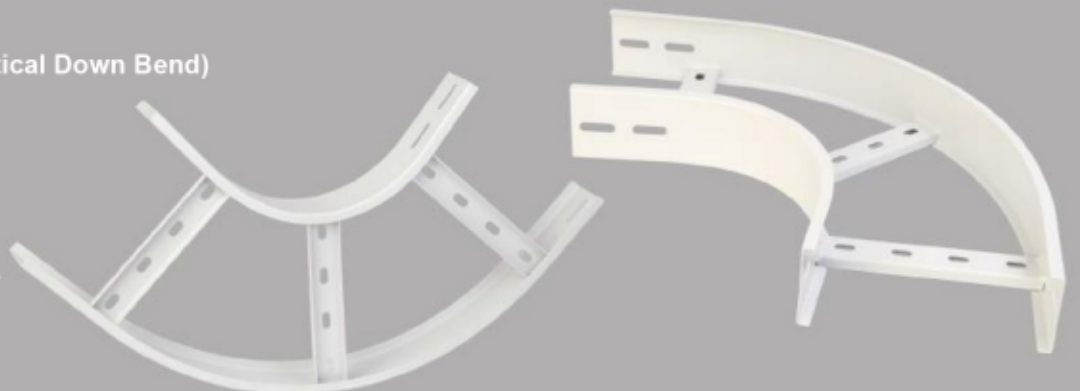
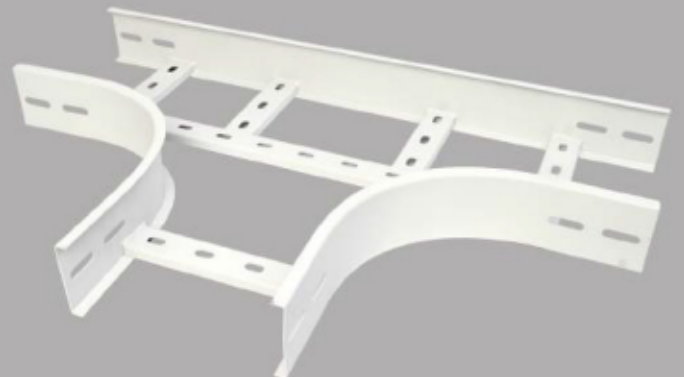
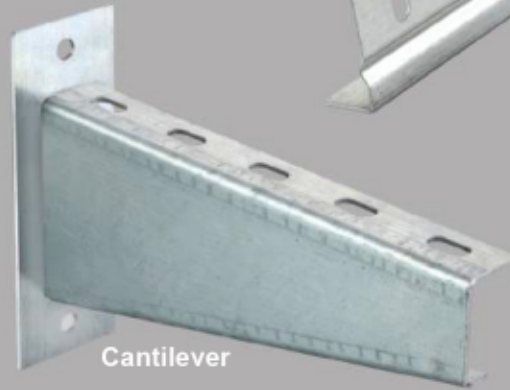
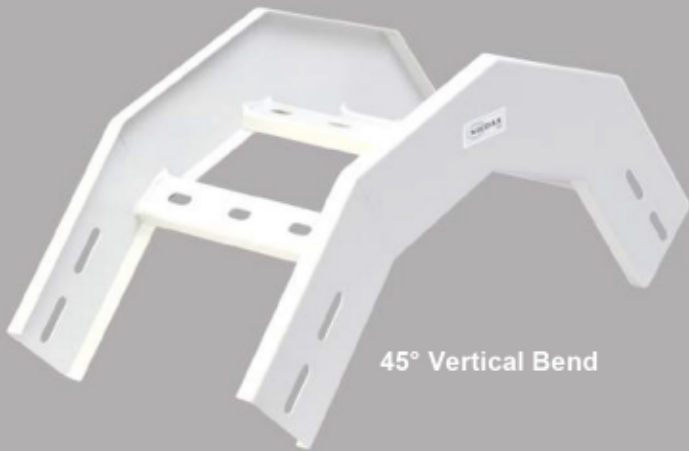
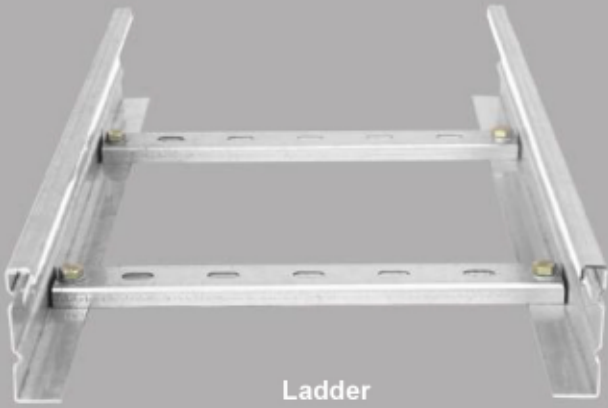

**EU DECLARATION OF CONFORMITY**

(As per Low Voltage Directive 2014/35/EU Annex III – Para 3)

**Manufacturer/Assembler:** Niedax India Cable Management Systems Private Limited  
Plot No. 143/C-4, Bommasandra Industrial Area,  
Hosur Road, Anekal Taluk, Bangalore, Karnataka – 560 099 (INDIA).  
Tel No.: +91-80-29766811  
Web: www.niedax.co.in

**Description of Items:** Cable Trays and Allied Accessories with support systems.  
(SS, HDG, Powder coated & Pre-Galvanized Type)

**Intended Application:** To support insulated cables.

We, Niedax India Cable Management Systems Private Limited, Bangalore hereby declare that the above product (Cable Trays and Allied Accessories with support systems) fulfills all of the relevant requirements of applicable EU Directive and details of which are contained in the Technical Construction File

**EU Directive Applied :**  
Low Voltage Directive 2014/35/EU

**The following harmonized standard were used.**

EN 61537:2007 : Management - Cable Tray Systems and Cable Ladder Systems.

This said product shall not be put into service along with any other equipment without establishing the conformity of the same to the corresponding EU directives.

The criteria for selection safety requirements of other associated equipments and installation guidelines are detailed in the Instruction Manual.

**Marking:** 

**Year of First CE Marking:** 05/2019

**Year of Manufacture:** 03/2018

**AUTHORIZED SIGNATORY:**

**Name :** Mr. Arshad Hussain  
**Position :** Managing Director  
**Date. :** 29.05.2019  
**Place :** Bangalore

  
Signature

**First CE  
Certified  
Cable Tray  
Manufacturer  
in India...**

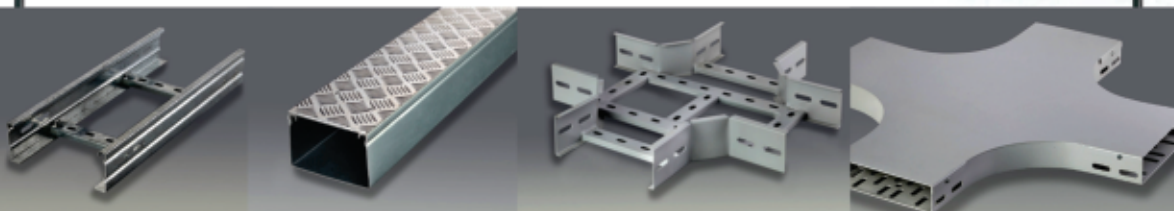

**TEST REPORT**
**Report No. : MAN:HL:1348005583**
**DATE : 15<sup>th</sup> July, 2022**

**NIEDAX INDIA CABLE MANAGEMENT SYSTEM PVT. LTD**  
 143/C-4 BOMMASANDRA INDUSTRIAL AREA HOSUR MAIN ROAD  
 ANEKAL TALUK, BANGALORE- 560099  
 INDIA  
**CONTACT PERSON : AADITH**

**THE FOLLOWING SAMPLE(S) WAS/WERE SUBMITTED AND IDENTIFIED BY/ON BEHALF OF THE CUSTOMER AS :**

<b>SAMPLE DESCRIPTION</b>	HOT DIP GALVANIZED CABLE TRAY
<b>COLOUR</b>	ZINC BLUE
<b>ORDER NO.</b>	202205/01559
<b>COUNTRY OF DESTINATION</b>	INDIA
<b>COUNTRY OF ORIGIN</b>	INDIA
<b>SAMPLE RECD ON</b>	28/06/2022
<b>TEST PERFORMING DATE</b>	28/06/2022 TO 14/07/2022

**TEST REQUESTED** Two hundred and twenty-three (223) substances in the Candidate List of Substances of Very High Concern (SVHC) for authorization published by European Chemicals Agency (ECHA) on and before Jan 17, 2022 regarding Regulation (EC) No 1907/2006 concerning the REACH.

**SUMMARY:**

According to the specified scope and analytical techniques, concentrations of tested SVHC are ≤ 0.1% (w/w) in the submitted sample.	<b>PASS</b>
-------------------------------------------------------------------------------------------------------------------------------------	-------------

**TEST METHOD & RESULT(S)** PLEASE REFER TO NEXT PAGE(S)

Per Pro SGS India Pvt. Ltd.



**SANDIP BHUSHAN (Technical Manager)**

**Authorized Signatory**

Email your Test Report Related Enquiries at [Feedback.HLT@ss.com](mailto:Feedback.HLT@ss.com)



**INSTITUTE OF TESTING AND CERTIFICATION  
(INDIA) PVT. LTD.**

Sr. No.	Requirement/Conditions	Result/Remarks	Verdict
1	<b>Wind Load Test</b>		
-	V is the wind speed (m/s) V: 28 m/s Wind impact Points: 4	In Compliance During the Test, sample was intact and no damage was observed.	P
-	After the Test, there shall be no visible failure impairing the safety.		P

**Test Setup**

\*\*\*\*\*END OF REPORT\*\*\*\*\*

Institute of Testing and Certification  
(India) Pvt. Ltd.

Test Report No.-ITC/TEST/NN/2205/18

Page 4 of 4

  
Authorised Signatory



**BUREAU  
VERITAS**

Bureau Veritas Certification

**NIEDAX INDIA CABLE MANAGEMENT  
SYSTEMS PVT. LTD.**

 PLOT # 143/C-4, BOMMASANDRA INDUSTRIAL AREA, HOSUR ROAD,  
ANEKAL TALUK, BANGALORE – 560 099, KARNATAKA, INDIA.

*Bureau Veritas Certification Holding SAS – UK Branch certifies that the Management System of the above organization has been audited and found to be in accordance with the requirements of the Management System standards detailed below.*

*Standards*
**ISO 9001:2015 & ISO 45001:2018**
*Scope of certification*
**DESIGN, DEVELOPMENT, MANUFACTURING AND SUPPLY OF  
CABLE SUPPORT SYSTEMS.**

Original cycle start date:	<b>15 October 2020</b>
Expiry date of previous cycle:	<b>Not Applicable</b>
Certification Audit date:	<b>25 August 2020</b>
Certification cycle start date:	<b>15 October 2020</b>

 Subject to the continued satisfactory operation of the organization's Management System, this certificate expires on: **14 October 2023**

 Certificate No. **IND.20.3212/IM/U** Version : 1 Revision date: **15 October 2020**

**Signed on behalf of BVCH SAS – UK Branch**  
**Jagdheesh N. MANIAN**  
**Head – CERTIFICATION, South Asia**  
**Commodities, Industry & Facilities Division**



0008

 Certification body address: **5th Floor, 66 Prescot Street, London, E1 8HG, United Kingdom.**

 Local office: **Bureau Veritas (India) Private Limited (Certification Business)  
72 Business Park, Marol Industrial Area, MIDC Cross Road "C",  
Andheri (East), Mumbai – 400 093, India.**

Further clarifications regarding the scope of this certificate and the applicability of the management system requirements may be obtained by consulting the organization.  
To check this certificate validity please call **+91 22 6274 2000**.



# STANDARDS & CERTIFICATES



Ref: BVIPL: SPL: BL/875(b)/3/2018  
 Test Order dated: 10.3.18

Date : 13.3.2018



M/s Niedax India Cable Management Systems Private Limited  
 # 1007, Level 10, Prestige Meridian I  
 No. 29, M.G. Road, Bangalore 560 001

**TEST REPORT ON CABLE TRAY SAMPLE**

Source of sample : Sample supplied by the customer  
 Customer Reference : Letter dated 10.3.18  
 UIN : 18008650  
 Project\* : Not furnished  
 Date of test : 12.3.18  
 Sample description\* : Ladder Type Cable Tray  
 Size of the sample\* : 300 (W) x 75 (H) x 2500 mm (L) & 2 mm thick  
 Span : 2350 mm  
 Bearing : 75 mm  
 Condition of sample : Satisfactory  
 Test Method : NEMA VE 1 (National Electrical Manufacturers Association)

**LOAD TEST :**

Sl. No.	Applied Load (kg)	Central Deflection (mm)	Observation
1	0	0	No Permanent Deformation Observed
2	40	2.15	
3	80	4.10	
4	120	6.15	
5	160	7.65	
6	200	9.45	
7	240	11.00	
8	280	12.70	
9	320	14.50	
10	360	16.20	
11	400	17.85	
12	440	19.10	
13	460	20.12	
14	460 kg (After 15 minutes)	20.12	
15	Residual (0 kg) (After 15 minutes)	1.4	
16	Max. Failure Load (kg)	720	Permanent Deformation Observed

\* As furnished by the customer

Note: 1. The results relate only to the items tested.  
 2. Report shall not be reproduced, except in full, without the written approval of the lab.  
 3. Any correction invalidates this report.

for **BUREAU VERITAS (INDIA) PRIVATE LIMITED**  
**Construction Services Laboratory**



  
**SANJEEV PATGAR**  
 Manager LAB

13/03/2018

Regd. Off : 72 Business Park, Ground Floor  
 Marol Industrial Area, MIDC, Cross Road 'C'  
 Andheri (East), Mumbai - 400 093, INDIA  
 Tel.: +91 22 62742000 Fax: +91 22 62742008  
 www.bureauveritas.co.in  
 CIN: 1174310MHA39501997C134363

Offices/Labs at: Ahmedabad, Baroda  
 Bhopal, Chennai, Cochin, Coimbatore  
 Delhi, Goa, Hubli, Hyderabad, Indore  
 Jaipur, Kakinada, Kandla, Kolkata, Ludhiana  
 Mangalore, Nagpur, Nashik, Pune, Raipur  
 Cross Tel: 020 41504000000



**OMEGA INSPECTION & ANALYTICAL LABORATORY**  
 T.S. No. 57,58 & 35, 36 GUINDY INDUSTRIAL ESTATE, GUINDY, CHENNAI - 600 032, TN, INDIA.

ISO/IEC 17025 : 2005 Accredited by NABL, (A Constituent Board of Quality Council of India)  
 For Chemical, Mechanical, Metallography, NDT, Water, Building Materials Test Etc.,

**Test Report** Page 1 of 1  
 Report Date : 02-03-2019

<b>Customer:</b> M/S NIEDAX INDIA CABLE MANAGEMENT SYSTEMS PVT. LTD. Plot No.143/C-4 Bommasandra Industrial Area, Hosur Road Anekal Taluk, Bangalore - 560099	<b>TR.No. :</b> OIAL/2019/02-1389  <b>Sample Details :</b> 300 x 50 x 2mm Thk Sheet Sample Material : IS 2062 Gr.E250A
Our Ref. TOCR No : 19-852 Dt.27.02.2019 Party's Ref : DC No.268 Dt.27.02.2019 Nature Of Test : CHEMICAL & MECHANICAL TEST Test Method : ASTM E 415-17, JIS G1253-02 IS 1608-P1-18	ULR No: TC624719000002621P  Sample Drawn By : Customer Test Started On : 28-02-2019 Test Completed On : 02-03-2019

**Test Results**

EQUIPMENT USED : OES-FOUNDRY MASTER-PRO, OXFORD, GERMANY

SPEC.FOR IS:2062/2011 Gr.E250 Quality "A" ACTUAL VALUES

	Min.	Max.			
CARBON	:-	0.23	%	0.13	%
MANGANESE	:-	1.50	%	0.56	%
SILICON	:-	0.40	%	0.12	%
SULPHUR	:-	0.045	%	0.015	%
PHOSPHOROUS	:-	0.045	%	0.014	%
CE	:-	0.42		0.31*	

EQUIPMENT USED : UTM, Model : UTN 40.SR No. : 11/98 - 2450. Make : FIE.

SPEC.FOR IS:2062/2011 Gr.E250 Quality "A" (MIN) ACTUAL VALUES

TENSILE STRENGTH IN MPa	:	410	488
YIELD STRESS IN MPa	:	240	339
ELONGATION IN GL OF 50mm	:	23 %	34 %

REMARKS : THE ABOVE SAMPLE CONFORMS TO IS:2062/2011 Gr.E250 Quality "A" WITH RESPECT TO THE TESTED PARAMETERS CONCERNED.

-----CONCLUDED-----

  
**M. RANKUMAR**  
 ENGINEER  
 Tested / Verified By

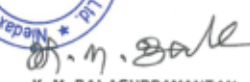

  
  
**K.M. BALASUBRAMANIAN**  
 CHIEF EXECUTIVE OFFICER  
 Authorised Signatory

Note : Certified that the test enumerated above have been carried out in conformity with standard Testing procedures and relevant specifications. The Certificate refers ONLY to the particular sample(s) submitted for Test. \*Indicates non accredited range. The sample details are as per customer description. All Complaints about this should be communicated in writing within 15 days from the date of issue of this report. The report shall not be reproduced in part /full without the approval of OIAL.

Form No.: QF-5-10-01

# PRODUCTS STANDARDS & PERFORMANCES

IEC / EN-61537  
NEMA-VE1

## Thinner Profile Design is much Stronger than Thicker Standard Design

Test product : Cable Ladder (Conventional)	Span (m)	Load at Span(Kg)	Test product : Cable Ladder ( Profile)	Span (m)	Load at Span (Kg)
Thickness : 2 mm	1	1536	Thickness : 1.5 mm	1	2995
Size of the product : 200 x 75 mm (W x H)	1.5	683	Size of the product : 200 x 75 mm (W x H)	1.5	1331
	2	384		2	749
	2.4	267		2.4	520

### Load Bearing Capacity Comparison between Conventional & Profile Design Allowable Load Graph

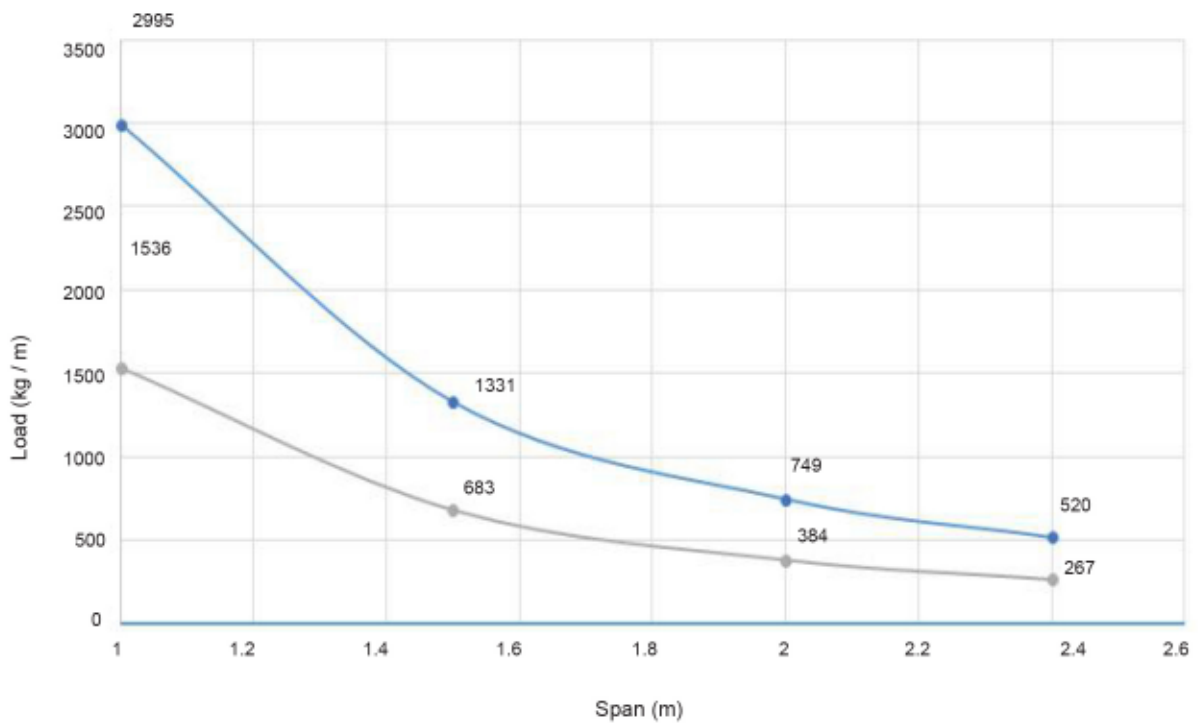

—●— Load at Span (Conventional Design) with 2 mm thickness  
—●— Load at Span (Profile Design) with 1.5 mm thickness

## Load Bearing Test Report of Profile Design Cable Ladder

Test product	Cable Ladder (Profile Type)
Size of the product	300 x 75 x 2500 mm
MOC	CRCA
Thickness	1.5 mm
Span	2400 mm
Bearing	50 mm
Reference Standard	NEMA VE 1

Sl. No.	Applied Load (Kg)	Deflection (mm)
1	0	0
2	10	0
2	20	1
3	30	1
4	40	1
5	50	2
6	60	2
7	70	3
8	80	3
9	90	3
10	100	4
11	110	4
12	120	5
13	130	5
14	140	6
15	150	7
16	160	7
17	170	7
18	180	8
19	190	9
20	200	9
21	210	10
22	220	10
23	230	10
24	240	10
25	250	11
26	260	11
27	270	12
28	280	12
29	290	13
30	300	13
31	310	14
40	Breaking Load	780 Kg

No Permanent Deformation Observed

Permanent Deformation Observed

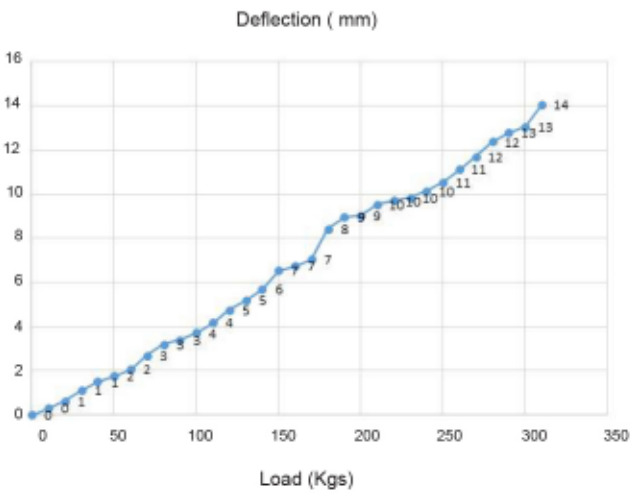

# GLOBAL PRESENCE

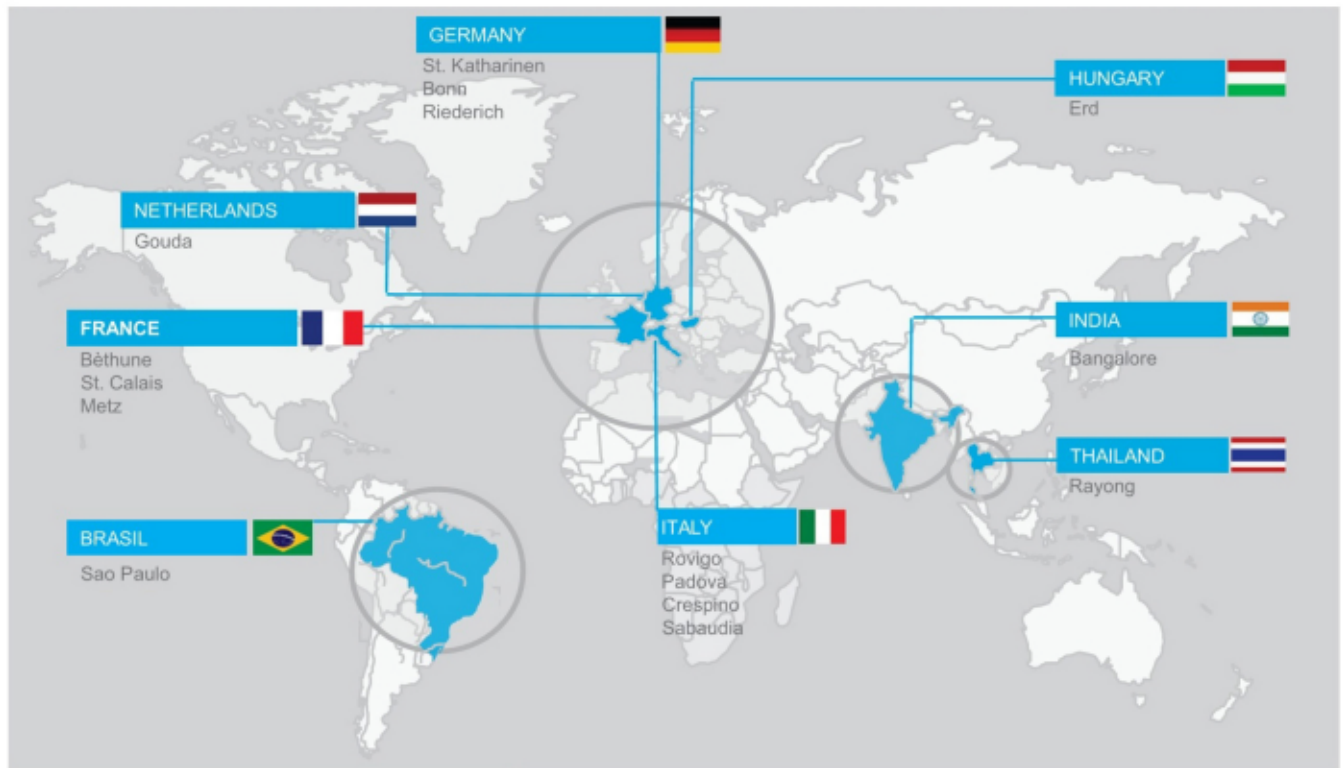

21 PRODUCTION SITES WORLDWIDE

## EUROPE

-  Niedax Germany, Linz/Rhein  
**3 Production plants**  
**4 Regional warehouses**
-  Niedax Hungary, Budapest  
**1 Production plant**
-  Niedax Czech Republic, Praha
-  Niedax France, Paris  
**3 Production plants**
-  Niedax Austria, Vienna
-  Niedax Ireland, Tralee  
**1 Production plant (Excel Electric, Dublin)**  
BVS-Niedax Norway, Oslo
-  Niedax Switzerland, Visp  
Zürich
-  Niedax Bulgaria, Sofia
-  JV Femi-CZ  
Steel Line CMS  
**4 Production plants**
-  Niedax Romania, Bukarest
-  Niedax Netherlands, Nijmegen  
Gouda  
**1 Production plant**
-  Niedax Spain, Madrid
-  Niedax Slovakia, Bratislava
-  Niedax Belgium, Gent
-  Niedax Poland, Tamowkie Góry
-  Niedax Russia, Moscow



## NO. & SO. AMERICA

-  Niedax North America, Columbus / Ohio
-  Niedax Mexico, Puebla
-  Niedax MOPA Brazil, Sao Paulo  
**1 Production plant**
-  Niedax Chile, Santiago
-  Niedax Peru, Lima
-  Niedax Canada, Québec

## ASIA & AUSTRALIA

-  Niedax Asia Pacific, Singapore
-  Niedax Thailand, Rayong  
**1 Production plant**
-  Niedax India, Bangalore  
**1 Production plant**
-  Vietnam, Ho Chi Minh City
-  Niedax Australia, Sydney

## UAE

-  Niedax Middle East FZE, Dubai
-  Niedax South Africa, Johannesburg

**80 DISTRIBUTION AGENCIES  
IN 34 COUNTRIES WORLDWIDE**

## Niedax India Cable Management Systems Pvt. Ltd.

Corporate Office: Plot No.143/C-4, Bommasandra  
Industrial Area, Hosur Road, Anekal Taluk, Bangalore - 560099  
Mob: +91-99-8642-8428/ +91-90-0137-4307  
Tel: +91-080-4116-1385 | info@niedax.co.in | www.niedax.co.in

