

Metal Expansion Joints with Floating Flanges

Style RMEJ-FF



DESIGN

Metal expansion joints are elastic pipe elements designed to provide compensation for expansion movements and vibrations in the pipe lines.

APPLICATIONS

These joints are mainly used in pipe lines for the conveyance of a liquid, gas or granular medium under lowest and highest temperatures involving a wide range of applications- Such as :

- EXHAUST PIPES OF ENGINES AND TURBINES
- SHIP INDUSTRY
- CHEMICAL AND PETRO
- CHEMICAL PLANTS
- POWER PLANTS
- CONSTRUCTION MACHINE INDUSTRY
- HYGIENIC APPLICATION IN FOOD INDUSTRY
- AIR CRAFT AND NUCLEAR INDUSTRY
- DISTRICT HEATING SYSTEM

ADVANTAGES

- COMPENSATES FOR AXIAL MOVEMENTS DUE TO THERMAL CHANGES
- COMPENSATES FOR TORSIONAL AND ANGULAR MOVEMENTS
- ISOLATES VIBRATIONS, DAMPENS NOISE AND PRESSURE SURGES
- FLOATING FLANGE EASES INSTALLATION
- THE FLUID DOES NOT COME IN CONTACT WITH THE FLANGE MATERIAL

EVERY JOINT IS TESTED FOR PRESSURE & VACUUM

for durability, long life & trouble free service

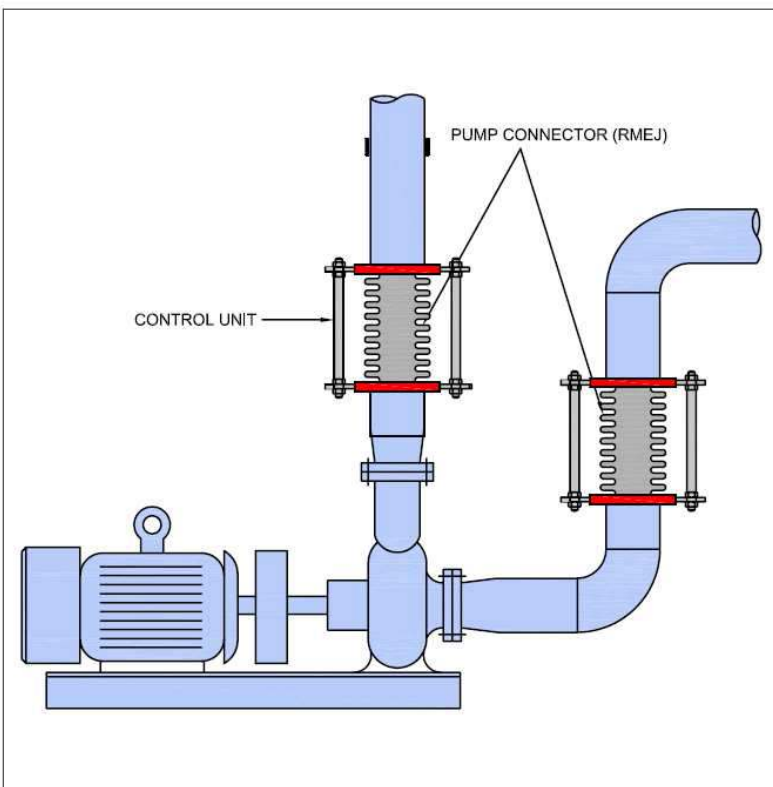

MEJ 600 MFF FEB 13

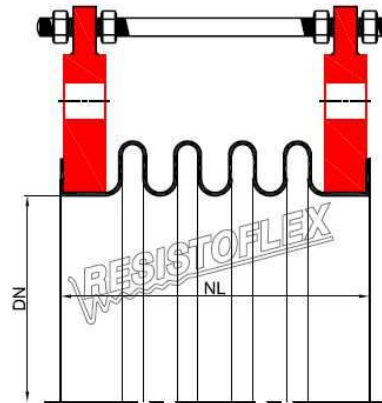

MEJ with Control Units for other lines

CONSTRUCTION

S.No.	Parts	MATERIAL	STANDARD	OPTIONAL
1	Flange	Carbon Steel	IS 2062	SS 304 / 316
2	Bellows	Stainless Steel	SS 304	SS 316
3	Sleeve (optional)	Stainless Steel	SS 304	SS 316
4	Control Units (optional)	Carbon Steel	IS 2062	SS 304 / 316
Application		Lines of water, compressed oil, steam, oil, chemicals etc.		
Medium		Water, Steam, Turbines, Fuel Oil, Gas, Air etc.		

DESIGN CONDITIONS

TYPE		PN 10	PN 16	PN 25
Maxm. Working Pressure	Kgf/cm ²	10	16	25
Test Pressure	Kgf/cm ²	15	24	38
Flange Drillings	Standard	BS 10 D	BS 10 E	IS 6392
	Optional	ASME B16.5 / BS 4504 / ISO 7005 / ES 1092		
Temperature	-30° C to +250° C			

* Control Units Recommended 1 bar = 1 Mpa = 1 Kg/cm² = 14.5 psi

TECHNICAL CHARACTERISTICS

CODE	NOMINAL BORE DN (mm)	NATURAL LENGTH NL (mm)	AXIAL MOVEMENT (mm)	LATERAL MOVEMENT (mm)	WORKING PRESSURE (kgf/cm ²)
RMEJ - FF 020	020	125	±10	±8	10 / 16 / 25
RMEJ - FF 025	025	125	±10	±8	10 / 16 / 25
RMEJ - FF 032	032	150	±10	±8	10 / 16 / 25
RMEJ - FF 040	040	150	±10	±8	10 / 16 / 25
RMEJ - FF 050	050	150	±10	±8	10 / 16 / 25
RMEJ - FF 065	065	150	±10	±8	10 / 16 / 25
RMEJ - FF 080	080	150	±10	±8	10 / 16 / 25
RMEJ - FF 100	100	150	±10	±8	10 / 16 / 25
RMEJ - FF 125	125	150	±10	±8	10 / 16 / 25
RMEJ - FF 150	150	150	±10	±8	10 / 16 / 25
RMEJ - FF 200	200	150	±10	±8	10 / 16 / 25
RMEJ - FF 250	250	200	±10	±8	10 / 16 / 25
RMEJ - FF 300	300	200	±10	±8	10 / 16 / 25
RMEJ - FF 350	350	200	±10	±8	10 / 16 / 25
RMEJ - FF 400	400	200	±10	±8	10 / 16 / 25
RMEJ - FF 450	450	200	±10	±8	10 / 16 / 25
RMEJ - FF 500	500	200	±10	±8	10 / 16 / 25
RMEJ - FF 600	600	250	±10	±8	10 / 16 / 25

• Suffix CU for RMEJ with Control Units • Consult Resistoflex for special sizes, end connections, conveying medium, operating Conditions

In the interest of continual development and improvement, the company reserves the right to make modifications to these details without notice